



# I PROGETTI CICLADDA E WHEST

**MOBILITÀ DOLCE E VALORIZZAZIONE TURISTICA  
DELL'ADDA LODIGIANO**

**APRILE 2024**



PROVINCIA  
DI LODI



PARCO  
ADDA SUD



# Il lodigiano: meta di turismo sostenibile

Il territorio lodigiano si sta scoprendo come meta privilegiata per un turismo sostenibile, con un occhio di riguardo per la **mobilità dolce** e la **valorizzazione ambientale**.

Al centro di questa trasformazione ci sono due progetti ambiziosi, che insieme mirano a creare un'infrastruttura integrata per la fruizione **turistica e culturale** dell'area.

// **CICLADDA**

// **WHEST (THE WHITE STORK WAY)**

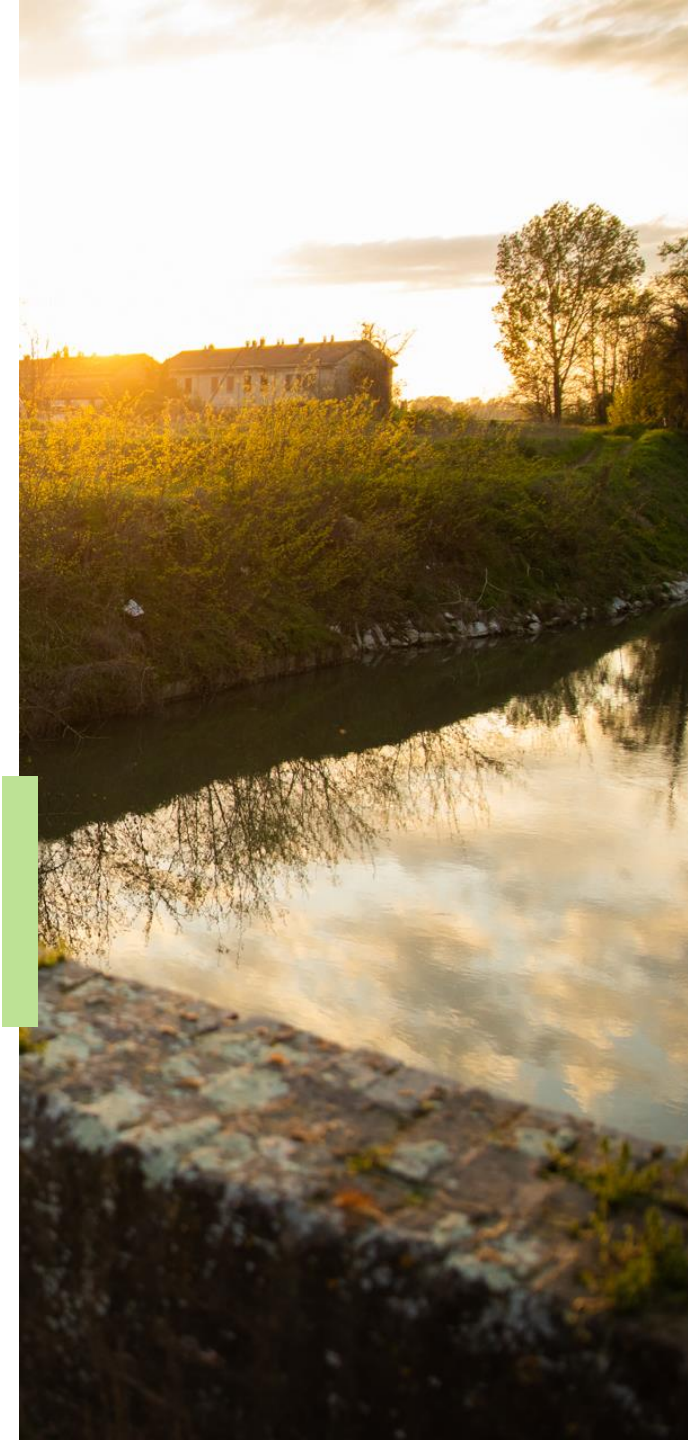

# Promozione della mobilità dolce

Sviluppare un sistema di **percorsi ciclabili e pedonali** che si integrano con **l'ambiente naturale** e le **risorse culturali**, migliorando la connettività tra le aree di interesse turistico.

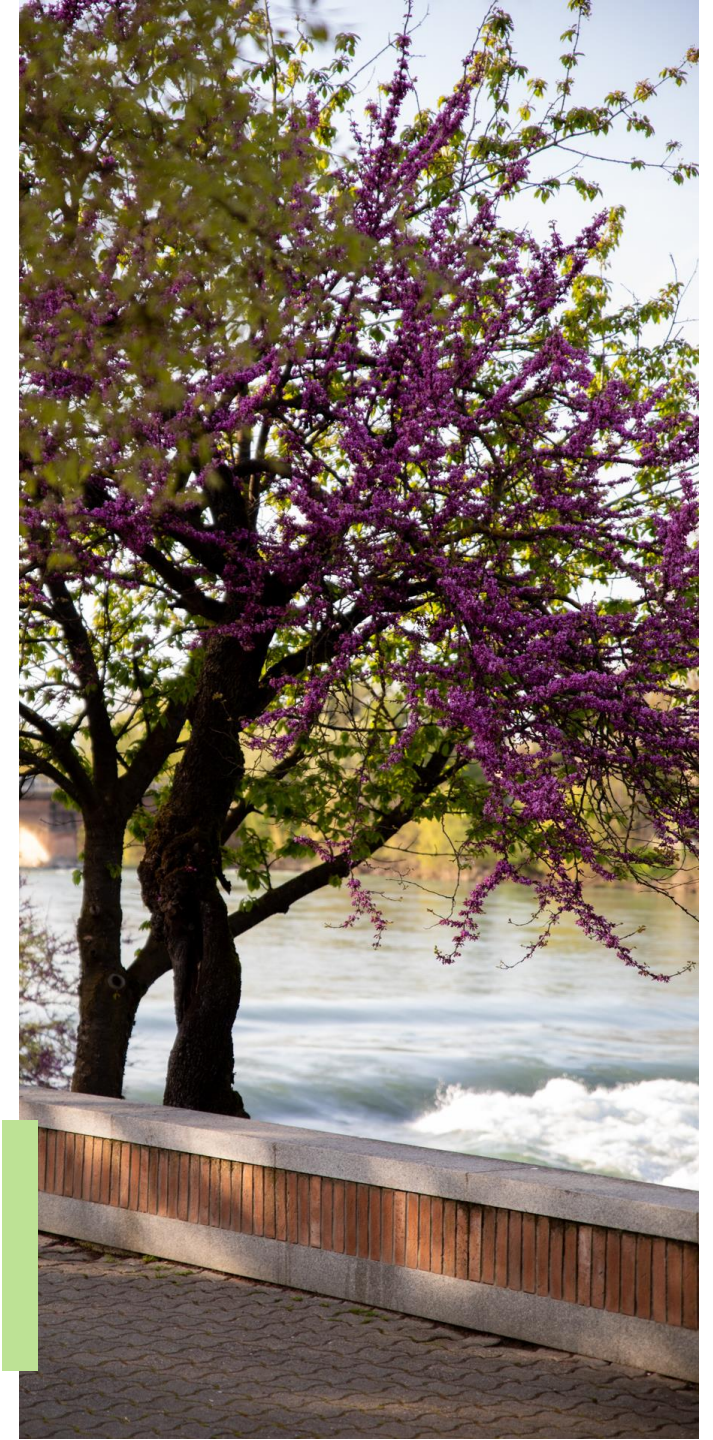



# Valorizzazione del Patrimonio Naturale e Culturale

Tutelare e promuovere la **biodiversità**, con particolare attenzione alla cicogna bianca (progetto WHEST), e il ricco patrimonio **storico, artistico e culturale** dell'area.

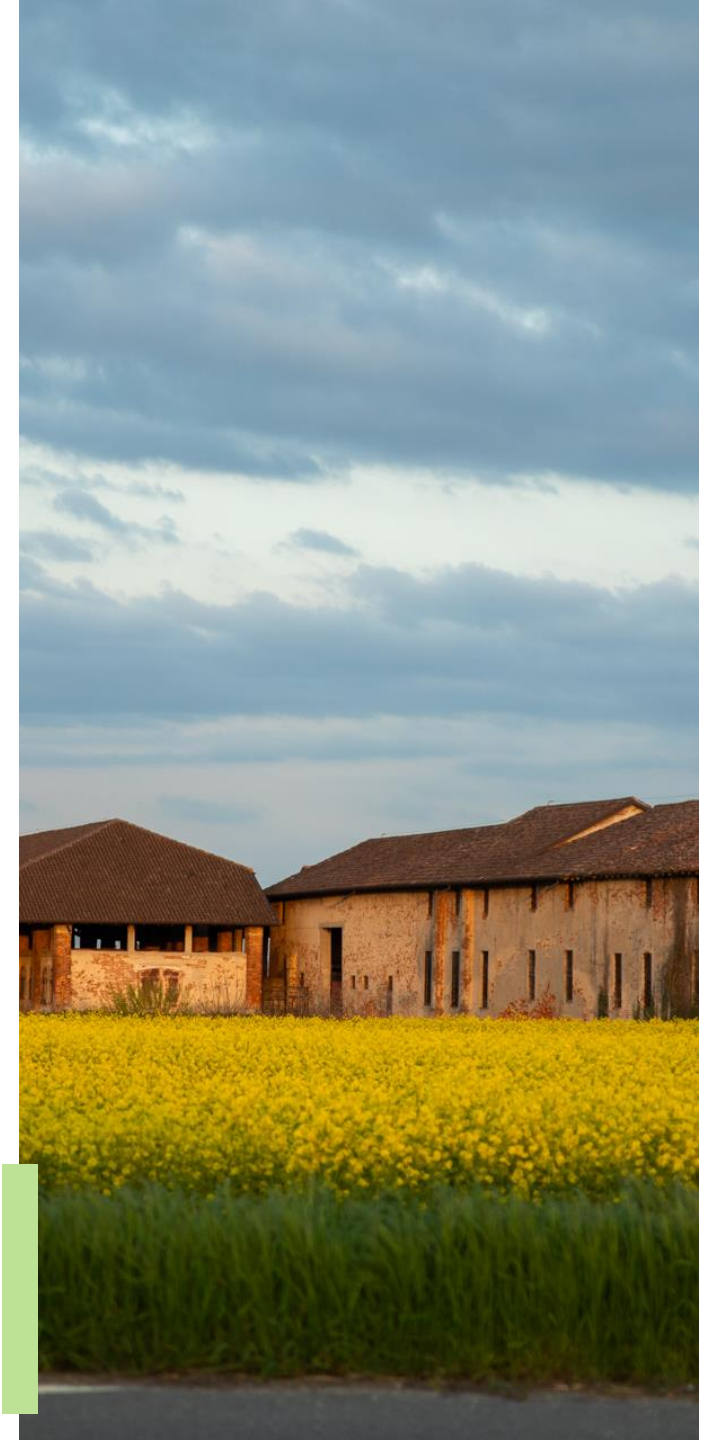

# Sviluppo Sostenibile del Territorio

Stimolare un turismo responsabile che contribuisca allo **sviluppo economico locale**, nel **rispetto dell'ambiente** e della **comunità**.

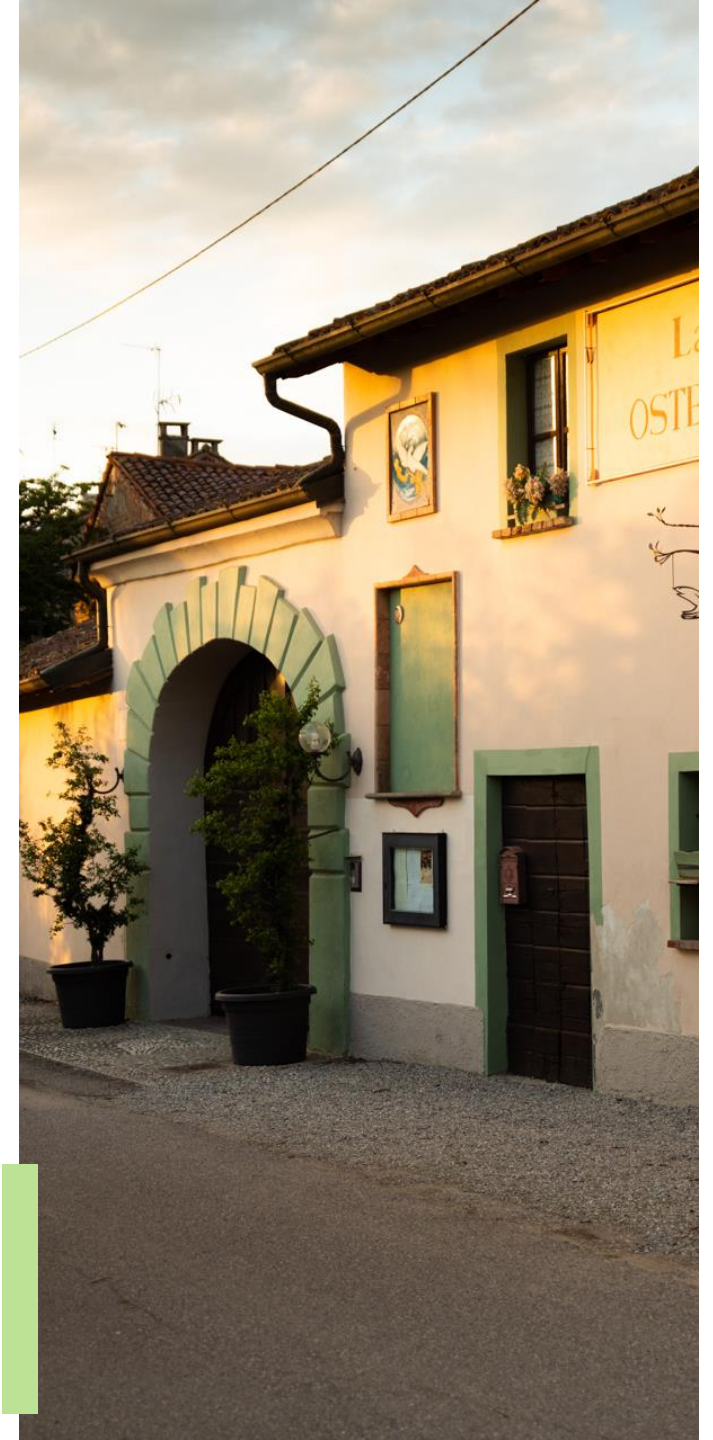

# Interventi

## // Integrazione di Percorsi Ciclabili

Collegare i principali punti di interesse attraverso itinerari sicuri e accessibili, arricchiti da aree di sosta tematiche e pannelli informativi.

## // Eventi e Iniziative di Promozione

Organizzare eventi culturali, naturalistici e sportivi per attirare visitatori e incentivare la scoperta del territorio.



## // Miglioramento delle Infrastrutture e dei Servizi

Implementare servizi di noleggio bici, punti di ristoro e info point per turisti, nonché migliorare la segnaletica e l'accessibilità dei percorsi.

## // Collaborazione con Enti e Associazioni Locali

Sinergie con il Parco Regionale dell'Adda Sud, associazioni ambientaliste, comuni e altri stakeholders per la realizzazione e promozione degli interventi.



## // INCREMENTO DEL TURISMO

Attrarre un numero maggiore di visitatori interessati al turismo ecologico e culturale e aumentare la permanenza media nel territorio.

# Risultati attesi

## // CONSERVAZIONE DELL'AMBIENTE

Miglioramento della qualità ambientale e promozione della biodiversità.

## // RIVITALIZZAZIONE ECONOMICA LOCALE

Stimolare l'economia attraverso l'incremento dell'ospitalità, della ristorazione e delle attività legate al turismo sostenibile.



PROVINCIA  
DI LODI



PARCO  
ADDA SUD

# Il progetto CICLADDA

Capofila



In partnership con



Sostenitori



Città di Lodi



Con il contributo di







# Il progetto WHEST

THE WHITE STORK WAY  
LA VIA DELLA CICOGNA BIANCA



Comune di  
Castiglione d'Adda

Sostenitori



Comune di Lodi

FIAB Lodi

Comune di San Martino in Strada

Auser Iodigiana

Comune di Cavenago d'Adda

Cooperativa Amicizia

Comune di Turano Lodigiano

Associazione Amici di Sissi

Comune di Mairago

Consorzio navigare l'adda

Comune di Bertonico

Lipu

Comune di Terranova dei Passerini

Enel

Comune di Castelgerundo

Confcommercio

Comune di Maleo

SAL – Società Acqua Lodigiana

Con il contributo di





# Aree di intervento



MILANO ●

CICLADDA

LODI ●

WHEST

PAVIA ●

CASTIGLIONE D'ADDA ●

CREMONA ●

PIACENZA ●



# Mappa concettuale

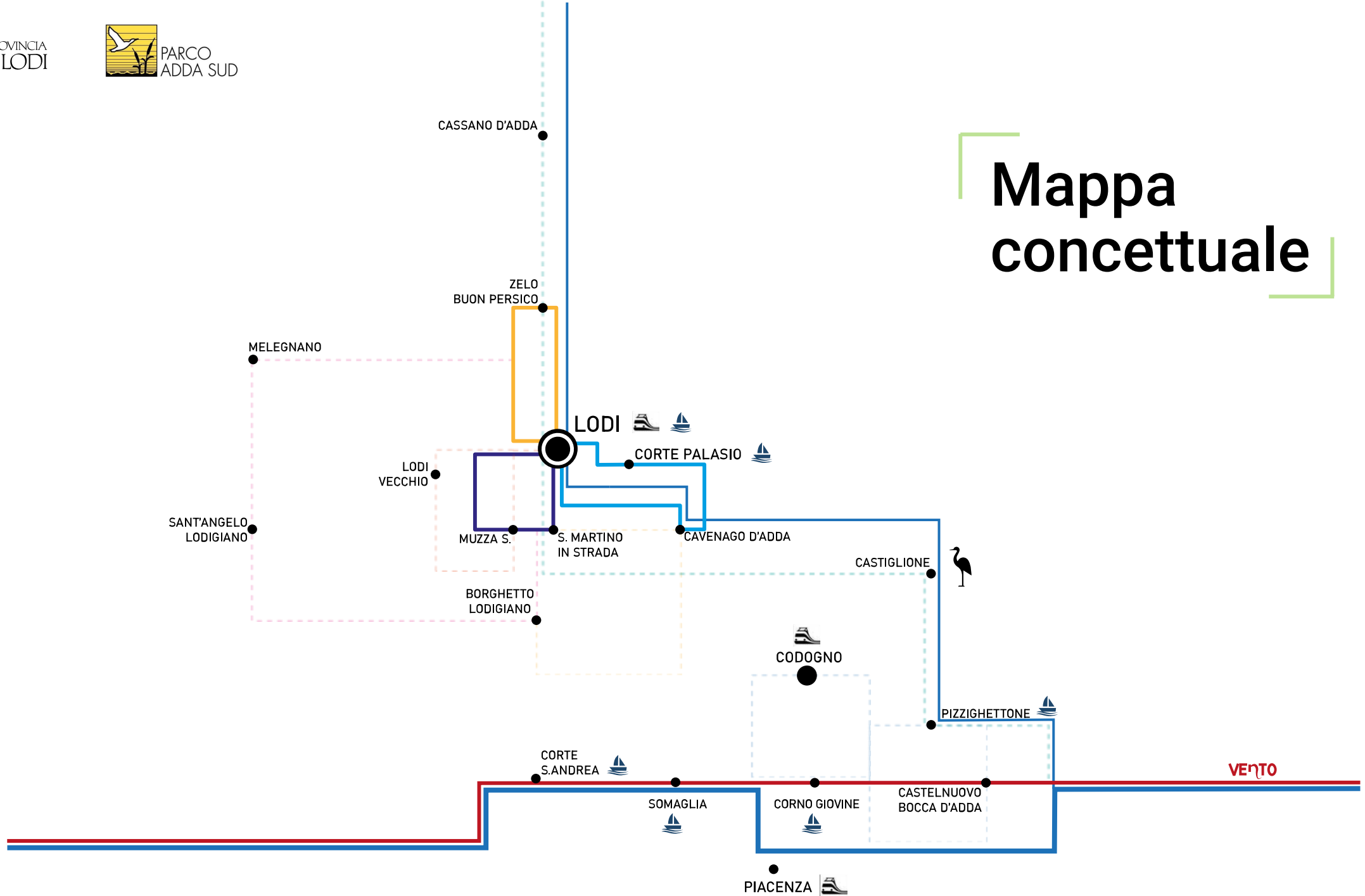

CICLADDA

# Da Zelo Buon Persico a Lodi

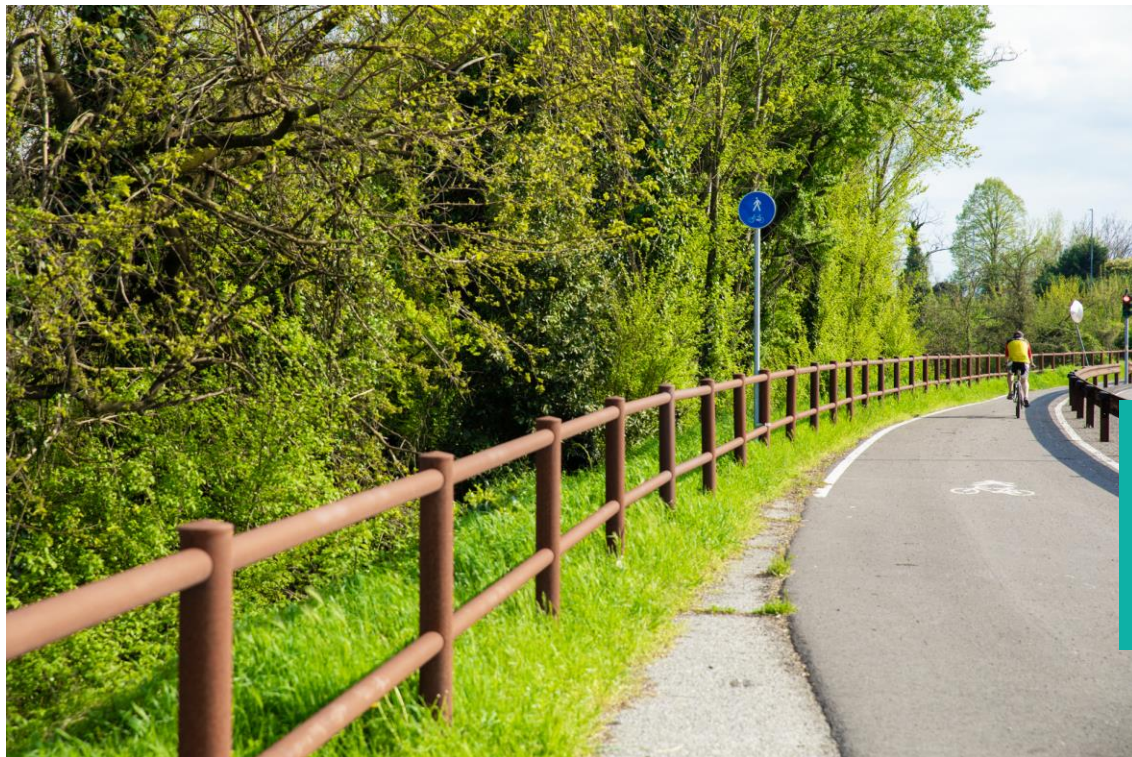



CICLADDA

# Lodi Lungoadda





# CICLADDA Lodi città

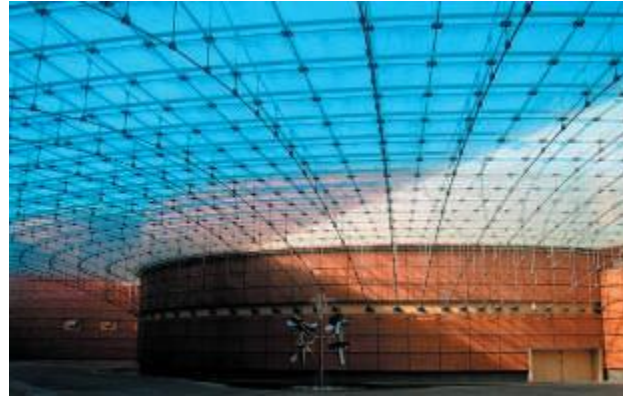



CICLADDA

# Corte Palasio e il nuovo attracco

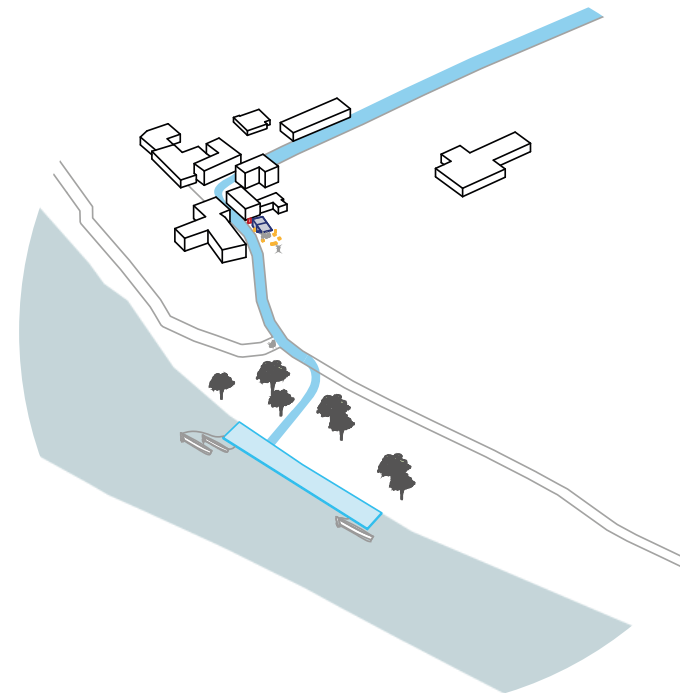
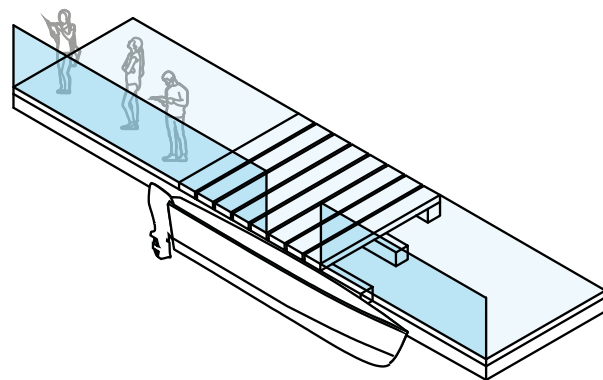

L'AREA È IN FASE DI STUDIO.  
LE IMMAGINI RIPORTATE SONO DELLE POSSIBILI SIMULAZIONI.

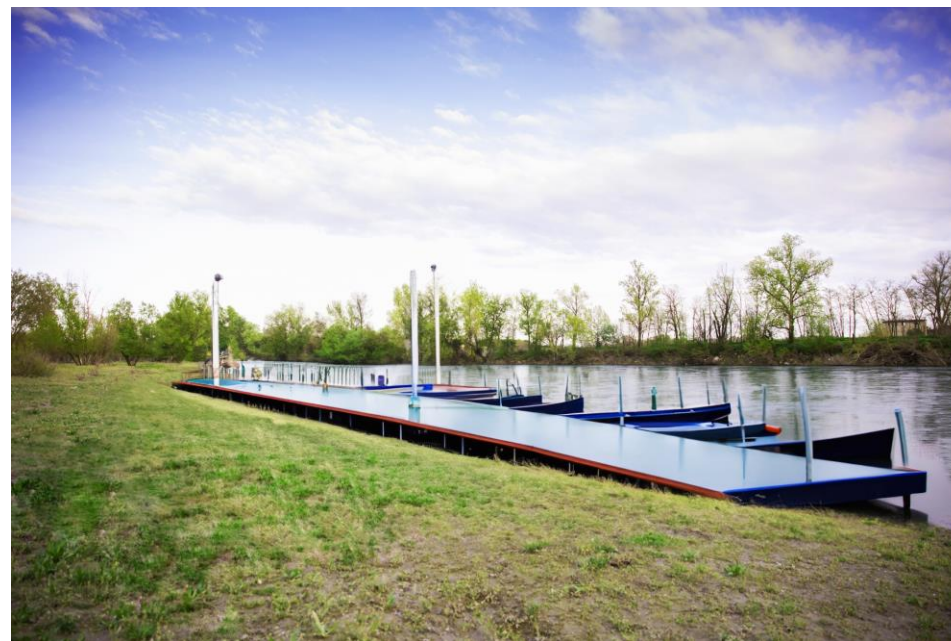



# WHEST Da Lodi a Castiglione d'Adda

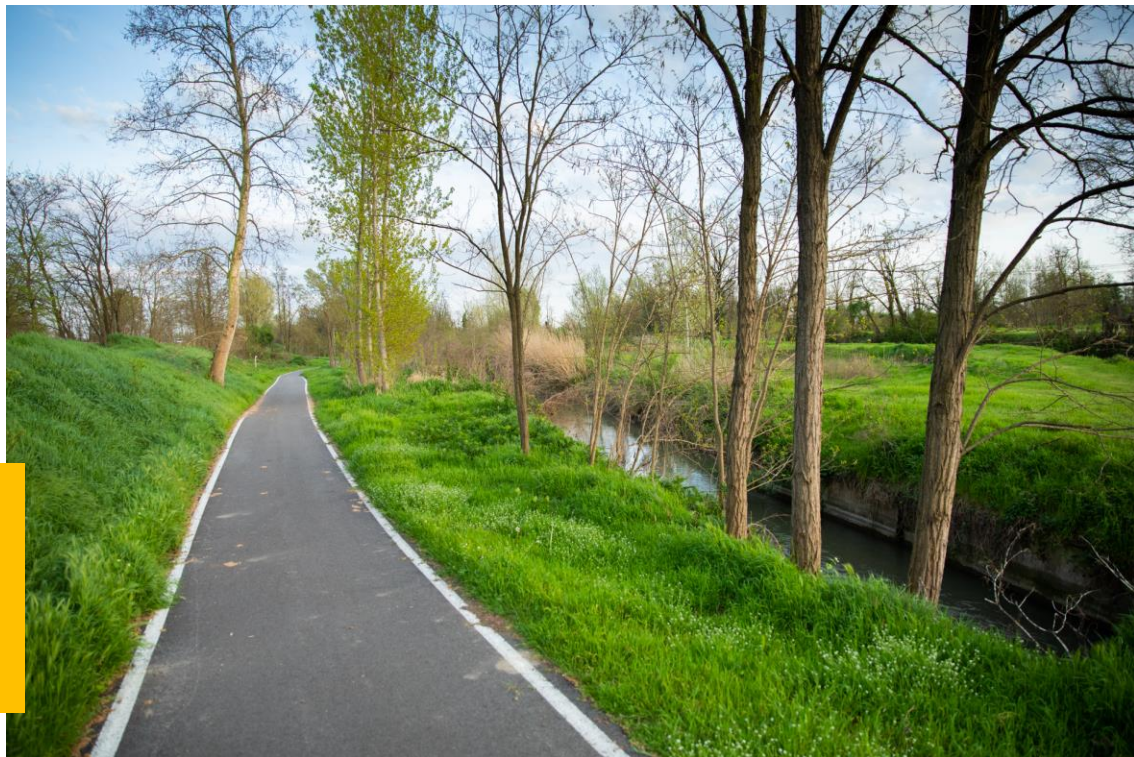



WHEST

# Centro Cicogne a Castiglione d'Adda





PROVINCIA  
DI LODI



PARCO  
ADDA SUD

# Cicladda: il logo.

CICLADDA



# Cicladda: simulazioni in fotoinsertimenti.





# Cicladda: simulazioni in fotoinserti.





# WHEST: il logo.



# WHEST: simulazioni in fotoinsertimenti.







PROVINCIA  
DI LODI



PARCO  
ADDA SUD

MILANO ●

# CICLADDA

● ZELO B.P.

CORTE PALASIO

LODI ●

●



PAVIA ●

CASTIGLIONE D'ADDA ●

● CASTELGERUNDO

MALEO ●

● CREMONA

● PIACENZA

# Costi interventi

**CICLADDA**

€ 2.428.067,94 COSTI TOTALI PROGETTO

€ 908.269,47 CONTRIBUTO DI FONDAZIONE CARIPLO



€ 224.000,12 COSTI TOTALI PROGETTO

€ 112.000 CONTRIBUTO DI FONDAZIONE CARIPLO





# I PROGETTI CICLADDA E WHEST

**GRAZIE PER L'ATTENZIONE.**



PROVINCIA  
DI LODI



PARCO  
ADDA SUD